

# Journal of Composite Materials

<http://jcm.sagepub.com>

---

## **Design and Ballistic Testing of Ti 6Al 4V Matrix Composites**

Yabei Gu and Vitali F. Nesterenko

*Journal of Composite Materials* 2007; 41; 2313 originally published online Jul 2, 2007;  
DOI: 10.1177/0021998307075444

The online version of this article can be found at:

<http://jcm.sagepub.com/cgi/content/abstract/41/19/2313>

---

Published by:

 SAGE Publications

<http://www.sagepublications.com>

On behalf of:

American Society for Composites

**Additional services and information for *Journal of Composite Materials* can be found at:**

**Email Alerts:** <http://jcm.sagepub.com/cgi/alerts>

**Subscriptions:** <http://jcm.sagepub.com/subscriptions>

**Reprints:** <http://www.sagepub.com/journalsReprints.nav>

**Permissions:** <http://www.sagepub.com/journalsPermissions.nav>

# Design and Ballistic Testing of Ti-6Al-4V Matrix Composites

YABEI GU\*

*Graduate Aeronautical Laboratories, California Institute of Technology  
1200E California Blvd, Mail Code 205-45, Pasadena, CA 91125, USA*

VITALI F. NESTERENKO

*Department of MAE, University of California San Diego  
9500, Gilman Dr. La Jolla, CA 92093, USA*

**ABSTRACT:** Ti-6Al-4V matrix composites enhanced by alumina tubes filled with boron carbide, alumina rods, and alumina plate is termed high gradient composite because of the big density differences among Ti-6Al-4V, alumina, and boron carbide materials. This high gradient composite has been developed for a theoretical study to help determine the best configuration for armor protection. This is the first attempt where materials are prepared using a powder processing method with the specific goal to address the ballistic performance. Hot isostatic pressing (HIP) was first used to manufacture ballistic grade Ti-6Al-4V alloy and high gradient composites incorporating Al<sub>2</sub>O<sub>3</sub> rods, plates, and tubes filled with B<sub>4</sub>C powders. Processing parameters were investigated and optimized based on materials properties. An important feature of powder-based materials is the lack of texture in comparison with traditional material. Several configurations of this high gradient composite were designed and tested by long rod penetration tests. High gradient composite materials demonstrated new damage patterning features during the long rod projectile penetration process. These features include projectile deflection, self-sealing of the hole, and forced shear localization in the direction of 45° to the impact line caused by fracture of Al<sub>2</sub>O<sub>3</sub> tubes on the initial stage of penetration process. Powder filled voids and rods induced volume distributed, highly heterogeneous pattern of damage initiated by cavities and their interactions. The test results are shown and analyzed in depth in this paper. The results prove that the powder-based approach can be used for processing of materials suitable for ballistic applications.

**KEY WORDS:** hot isostatic press (HIP), Ti-6Al-4V matrix composites, shear localization, long rod projectile testing.

---

\*Author to whom correspondence should be addressed. E-mail: [guy2@corning.com](mailto:guy2@corning.com)  
Figures 7 and 8 appear in color online: <http://jcm.sagepub.com>

## INTRODUCTION

**T**ITANIUM AND TITANIUM alloys are the design choice for aerospace, biomedical, and other applications because of an attractive combination of low density, high strength, ductility, high corrosion resistance, and biocompatibility. Hot isostatic pressing (HIP) is one of the most efficient techniques to develop high quality materials from the powders. This is the first attempt where materials are prepared using powder processing method with the specific goal to address the ballistic performance and high strain rate behavior. The results of the long rod projectile penetration test with tungsten (93%) heavy alloy penetrator on porous composite samples are presented. The fracture mechanisms under long rod impact are different in comparison with conical and blunt projectiles. The previous works on conical and blunt projectile tests were included in the previous publications [1–6]. Composite materials with alumina rods and tubes filled with  $B_4C$  powders demonstrate new features of penetration: projectile deflection with self-sealing holes and built-in mechanism of forced shear localization caused by the tube's fracture during the initial stages of penetration. The high gradient composites are able to deflect the projectile at the beginning of penetration. Powder filled voids and rods induced volume distributed, highly heterogeneous pattern of damage initiated by cavities and their interactions.

## PROCESSING OF HIGH GRADIENT COMPOSITE

Porous composites are called high gradient in our case because their components have quite different densities. Particularly, Ti–6Al–4V matrix has a density of  $4.46 \text{ g/cm}^3$ , solid alumina in the rod and in the wall of the tubes has a density of  $3.9 \text{ g/cm}^3$ , and  $B_4C$  powder inside the tube has a density of  $1.18 \text{ g/cm}^3$ . Another important feature of this material is the large scale of components (alumina rods, tubes comparable with the projectile diameter). The high-gradient composite materials are intended to deflect projectile at the early stages of penetration, and to activate 'horizontal' damage. This may prevent penetration, and introduce new channels of energy dissipation like bulk fracture of the target and projectile and comminuting of covalent ceramics in cavities. Another goal is the replacement of vertical shear banding resulting in easy plug formation by inclined and kinked shear banding. The main purpose of introducing powder filled voids and rods is to replace dominant shear bands running in the direction parallel to impact by complex, volume distributed, highly heterogeneous pattern of damage initiated by cavities and their interaction.

Composite samples with different configurations were prepared using  $Al_2O_3$  rods,  $Al_2O_3$  tubes (Coors AD995) filled with  $B_4C$  powders.  $Al_2O_3$  disks (Coors AD998) were also introduced. The rods (4.75 mm diameter) and tubes (outer and inner diameters are 4.75 and 3.175 mm) were placed into lattice with distances from the center in the horizontal and vertical directions equal to 10 and 5 mm, respectively (rod–tube–tube (RTT), Figure 1). In Figures 1–3, only the configurations of the  $Al_2O_3$  rod and  $Al_2O_3$  tubes are shown with the Ti support. The assembled  $Al_2O_3$  rods and the  $Al_2O_3$  tubes will be placed into the matrix materials which is Ti–6Al–4V powder. The matrix material is not shown in Figures 1–3. CP Ti plate was introduced only as a construction support for the rod and the tubes during the assembly process. The  $Al_2O_3$  rods and the  $Al_2O_3$  tubes are sitting inside the matrix materials and there

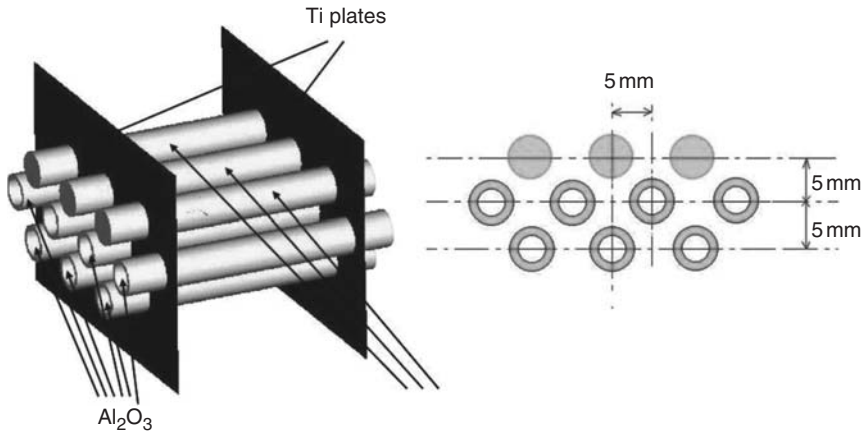

Figure 1. First configuration of HIPed composite samples (RTT).

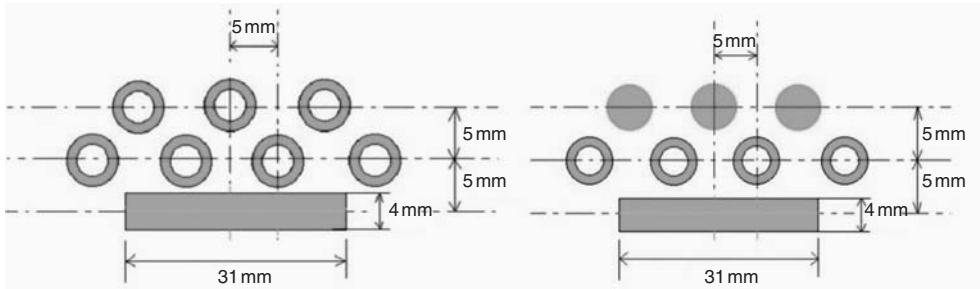

Figure 2. Different configurations of HIPed composite samples (TTP and RTP).

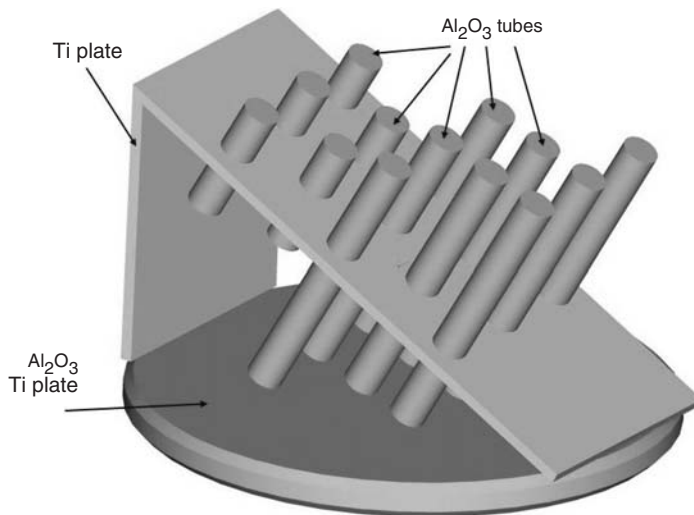

Figure 3. Configurations of HIPed angled tubes composite samples. The glass capsule is not drawn in this figure.

are no empty gaps among them except the area inside the tubes which is filled by porous  $B_4C$ .

Two titanium plates were used to hold the  $Al_2O_3$  rods and tubes inside the tapped Ti-6Al-4V powders. A punching die with perfect holes that have a slightly larger diameter was machined in order to achieve the exact position of our configurations. The tubes or rods were all introduced into the holes punched on the titanium plates before placement into the glass capsule. The non-milled powders were poured into the glass capsule during the process of assembly to hold the plates, rods, and tubes steady.

In the other two configurations (tube-tube-plate (TTP) and rod-tube-plate (RTP), Figure 2), two stacked  $Al_2O_3$  plates (31 mm diameter and 2 mm thickness each) were also placed at the bottom of the composite samples. These plates were placed first before introducing two rows of  $Al_2O_3$  rods and tubes above them.

For the angled tube composite (Figure 3), a  $45^\circ$  angle bent titanium plate was put on the top of the  $Al_2O_3$  plate (31 mm diameter and 2 mm thickness) in the first step. PREP non-milled (PNM) powder was poured into the glass capsule, which is not shown in the figure, and covered the  $Al_2O_3$  plates making them stable. The  $Al_2O_3$  tubes (3 and 1.5 cm) were inserted ( $45^\circ$  angle) into the pre-punched holes on the angled surface of the titanium plate and sit on the surface of the  $Al_2O_3$  plates after pouring prep non-milled powders. The powder that we poured first made it easy to insert the tubes into the systems without sliding along the holes.

## BALLISTIC EXPERIMENTAL RESULTS AND DISCUSSION

Set-up for long rod projectile testing on hot isostatically pressed (HIPed) materials are shown in Figure 4.

The samples (diameter 40 mm and thickness 30 mm) were shrink fitted into plates of alloy MIL-T-9047G. The samples from baseline material were taken from a 2-inch rod of MIL-T-9047G ( $\sigma_Y|_{\epsilon=0.02} = 979$  MPa, tensile strength 1055 MPa and elongation 15%). Penetrators from tungsten (93%W) heavy alloy with  $L/D = 10$  (mass 16.8 g, diameter 4.93 mm) were launched using the 20 mm smooth bore powder gun at the University of Dayton Research Institute (UDRI). The inclination (pitch and yaw) of a projectile is measured prior to impact with the flash X-ray system and a fiducial set-up similar to that described in an article by Rupert and Grace [7]. Velocity, pitch, and yaw for each test are presented in Table 1. These characteristics are especially important for long rod projectiles to ensure that differences in ballistic performance are due to the differences in materials properties. The definitions for pitch and yaw are taken from a paper written by Goldsmith [1,8] (Figure 5).

The samples after ballistic tests were cut normal to the orientation of the embedded  $Al_2O_3$  tubes or rods using Electrical Discharge Machining (EDM) or the diamond wire saw. If rod and tubes were placed far away from the impacted side they practically did not participate in defeat of the projectile (Figure 6).

This composite had the  $Al_2O_3$  rods closer to the surface of the impact at about 7.5 mm from the surface and 10 mm from the surface to the center of the  $Al_2O_3$  rods. A new feature was observed in this case. The projectile sealed the crater with heavily deformed remnants of the projectile (Figures 7 and 8). The geometry of rows of rods and porous tubes caused sever deformation of the penetrator and also changed the penetrator path (Figures 7 and 8).

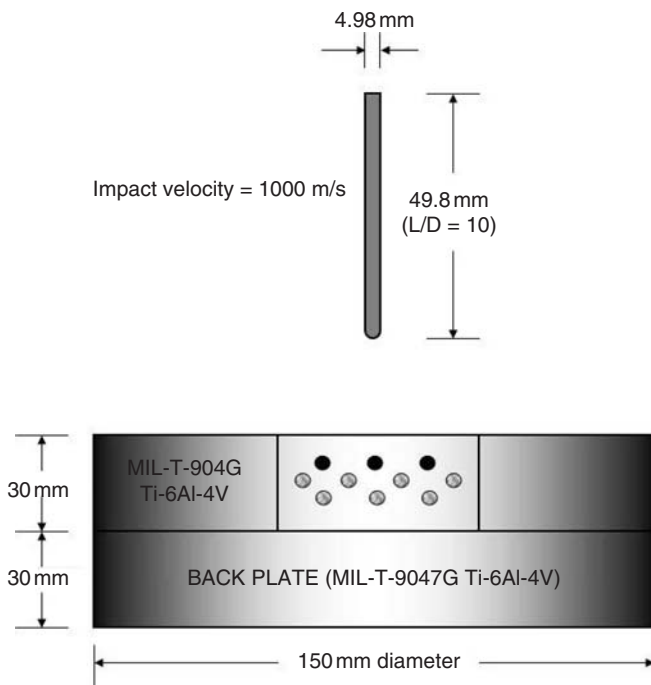

Figure 4. Experimental set-up for long rod projectile penetration testing of high gradient composite materials.

Table 1. Experimental data for long rod penetration tests.

No.	Materials	Impact velocity (m/s)	Pitch (°)	Yaw (°)
10469	Composite (RTT)	971	0.5	1
10470	Composite (RTT)	976	0.5	2.5
1-515	Composite (RTP)	1086	-	-
1-516	Composite (TTP)	917	-	-
1-517	Composite (Angled)	947	-	-
1-518	Composite (Angled)	1250	-	-

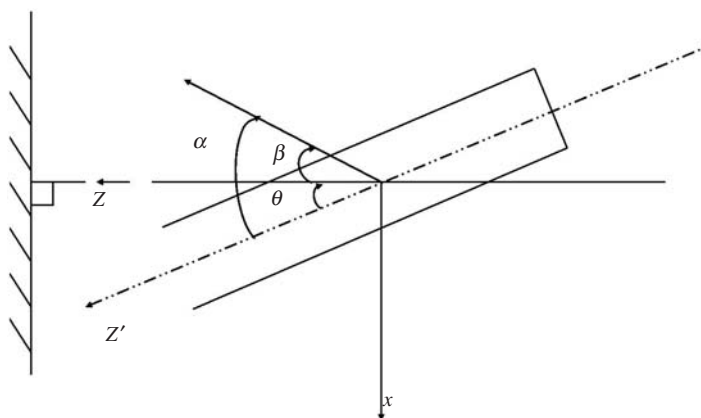
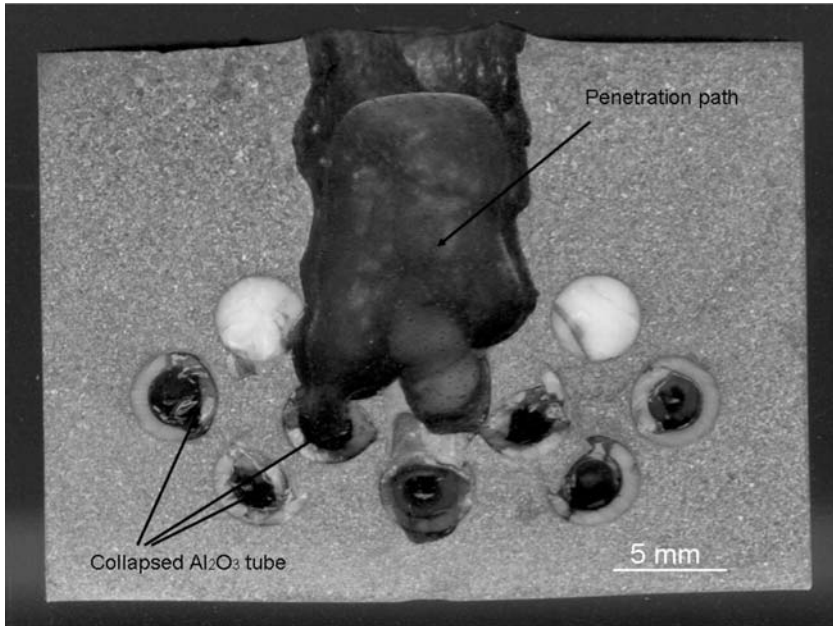
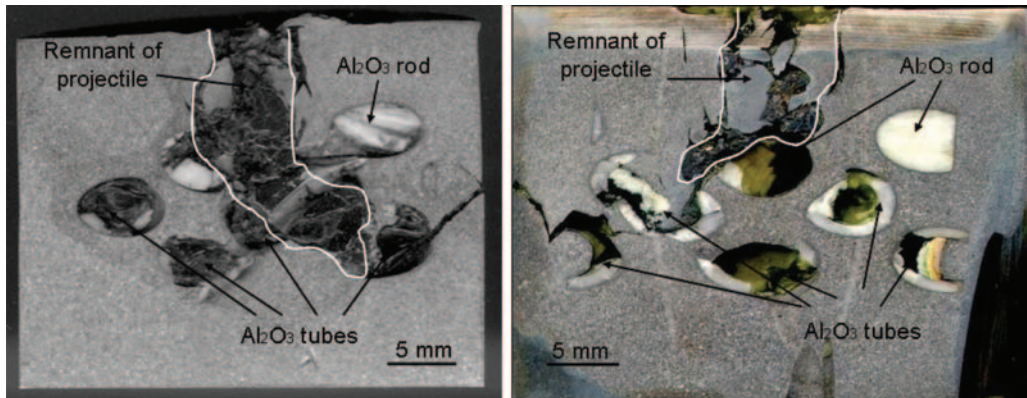

Figure 5. Definition of the yaw angle  $\alpha$ , pitch angle  $\beta$  and trajectory angle  $\theta$ .



**Figure 6.** Experiment with no deflection of the tungsten long rod projectile, test 10469.



**Figure 7.** Deflection of the tungsten projectile in test 10470.

The TTP and RTP configurations with addition of alumina plates were introduced in order to stop the projectile from penetration further into the target and to deflect the projectile (Figure 9).

It is interesting that the forced shear localization from the collapse of alumina tubes caused shearing even in the alumina rods (left figure in Figure 9). Rotation of penetrator due to inclined forced shear is evident on the right figure in Figure 9. Forced shear localization due to the collapse of alumina tubes is evident for both cases. As a result of side motion of the projectile induced by the built-in mechanism of shear localization, the penetrator is trapped inside the target reducing momentum transferred in comparison with homogeneous samples.

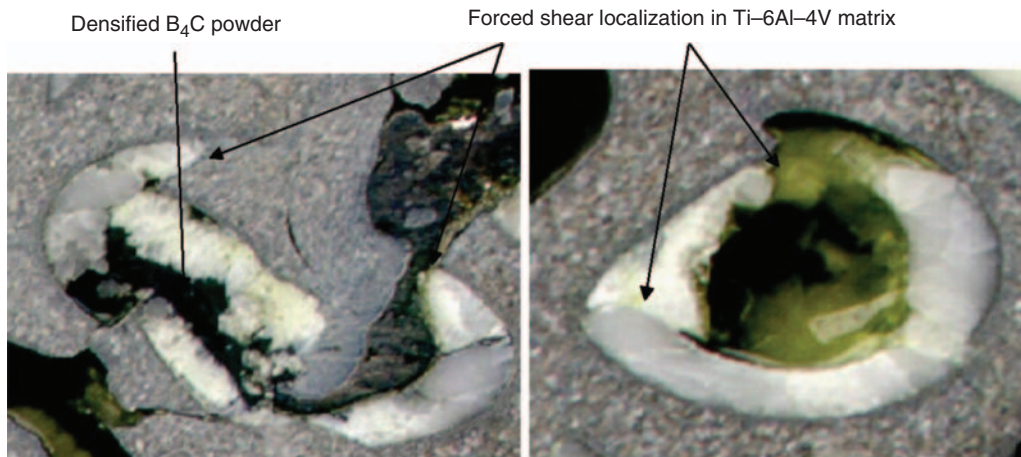

**Figure 8.** Forced shear localization in Ti-6Al-4V based high gradient composite caused by fracture of alumina tubes.

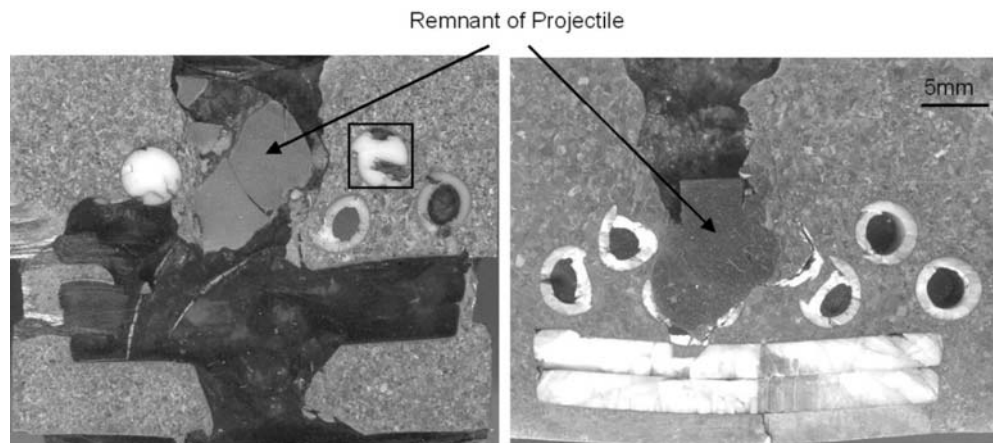
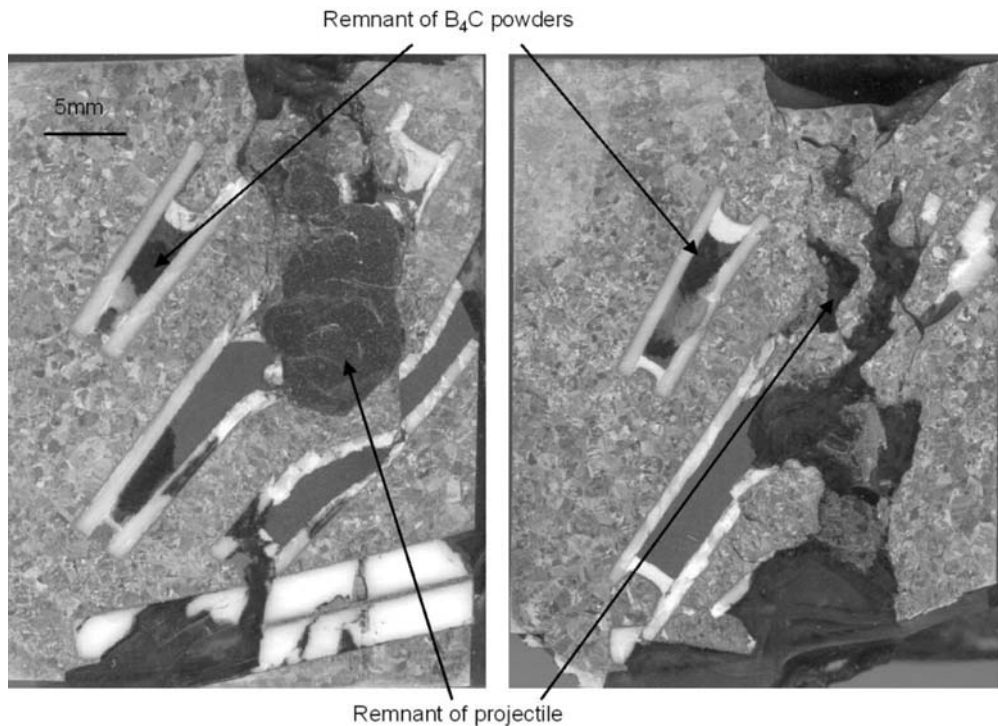

**Figure 9.** Tested RTP (rod-tube-plate) composites (left). Rotation of projectile is induced by built-in mechanism of shear localization (test 1-515) and tested TTP (tube-tube-plate) composites (right). Side motion of projectile is induced by built-in mechanism of shear localization (test 1-516).

The last configuration that we introduced is inclined alumina tubes with an alumina plate placed at the bottom. The purpose of introducing this geometry is to look at the projectile interaction with the inclined ceramic parts and to investigate how forced shear localization will be generated in this case. It was also expected that inclined tubes will ‘channel’ the projectile away from the impact line.

From Figure 10, we can see that, unfortunately, the penetrator went more or less straight into the samples, quite a different scenario in comparison with previous geometries (Figure 7). The penetration depth is relatively large and the alumina tubes encountered during the penetration were destroyed. There was still some forced shear localization due to the interaction between the penetrator and the alumina tubes, but the orientation of these shear bands does not follow  $45^\circ$  and practically follows the





**Figure 10.** Angled composites after ballistic test (tests 1-517 and 1-518).

penetration direction. In the left figure in Figure 10, one of the alumina tubes at the left side did not participate in the defeat, and did not generate forced shear localization despite being in the vicinity of entrance hole. The penetrator was shifted a little bit to one side and the entire body of penetrator sealed the entrance hole with a thickness about 25 mm deep. In the right figure, similar phenomena are also observed. But in this case the difference is that penetrator is broken into pieces in comparison with the case presented in the left figure in Figure 10. Penetrators do not follow the direction of inclined tubes.

In general angled configuration was less efficient in generating forced shear localization and projectile deflection in comparison with horizontal position of rods and tubes.

For high gradient composites, the significant difference from the homogeneous materials is that the fracture of the rods and tubes creates a larger volume involved in interaction with the projectile (Figure 7). In addition, the forced shear bands initiated by fracture of  $\text{Al}_2\text{O}_3$  tubes in the direction about  $45^\circ$  to impact line accompanied spontaneous shear bands resulting from instability of matrix materials. The shear bands are clearly transgranular (Figure 11).

The chemical component in the diffusion layer in interfacial layer between  $\text{Al}_2\text{O}_3/\text{Ti-6Al-4V}$  was found to be  $\text{Ti}_3\text{Al}$  by EDX.  $\text{Ti}_3\text{Al}$  is a brittle phase and causes crack under the ballistic testing in the interfacial layer. Figure 12 shows the characteristics of all those cracks that developed after the testing.

All the small cracks that were developed because of impact are at rest inside the reactive layer and very rarely develop further into the  $\text{Ti-6Al-4V}$  matrix. Those cracks were developed because the reactive layer is comparatively brittle in comparison with

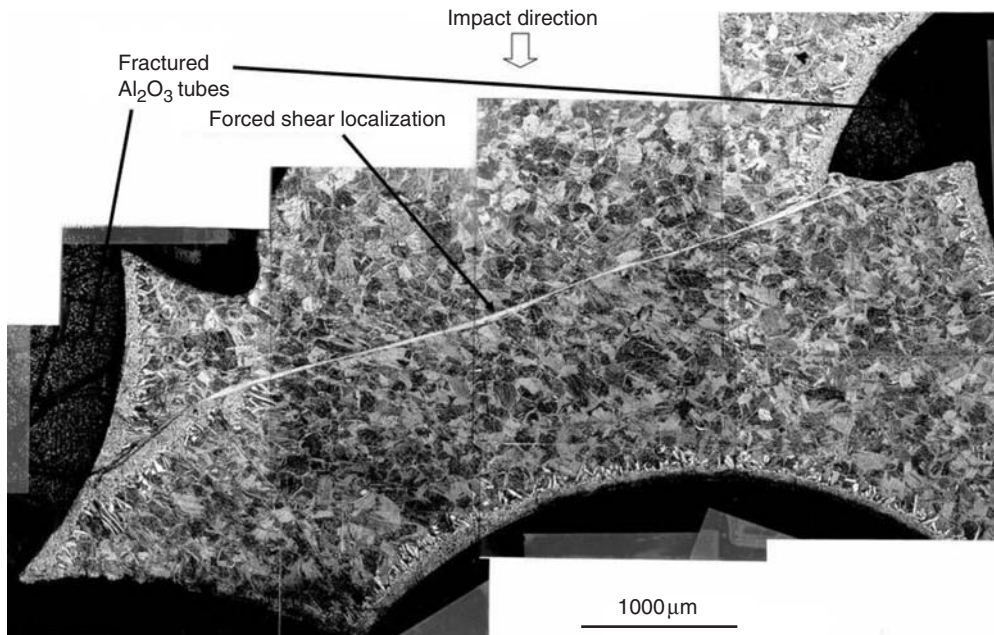

Figure 11. Shear localization developed in Ti-6Al-4V matrix.

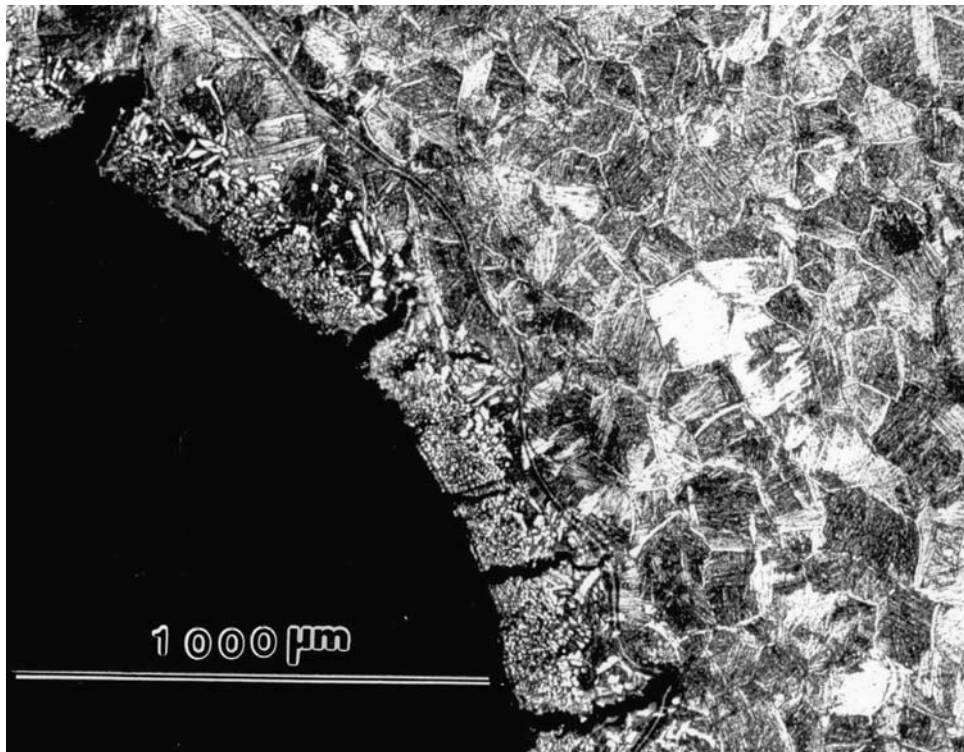
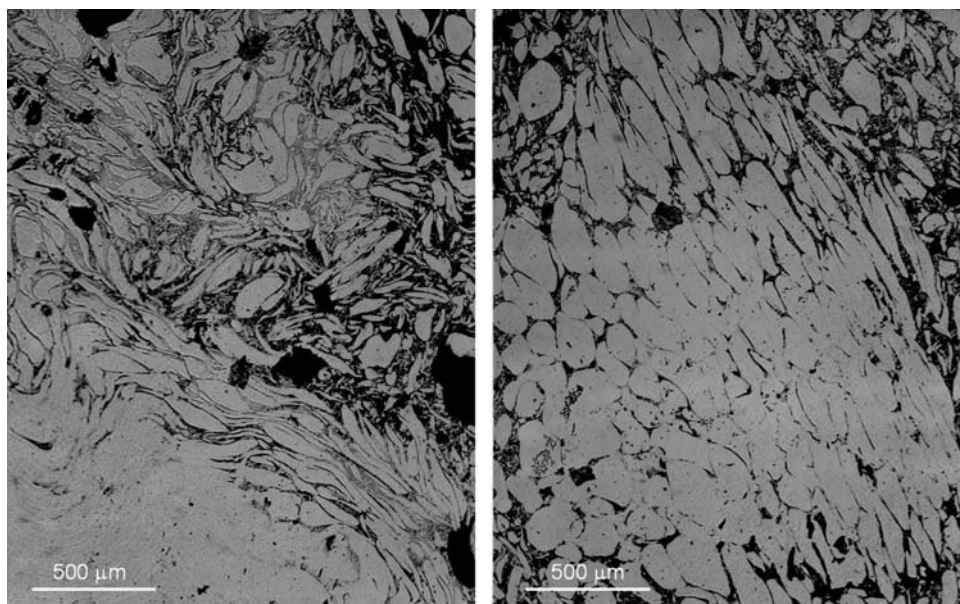

Figure 12. Local cracks in reactive layer.



**Figure 13.** Plastic deformation of tungsten projectile.

matrix material. Therefore, these small cracks do not have much effect on the overall properties of the high gradient composite.

In comparison with the homogeneous materials, the damaged volume participating in projectile deflection is relatively large. The localized plastic deformation of the tungsten projectile is a characteristic feature of the process (Figure 13). While the remnants of the projectile close to the entrance hole remained practically undeformed, extensive plastic deformation of the bended parts of the projectile is an additional source of the energy dissipation. Also, the energy absorption mechanism that is expected to be operative in composites is the comminution of the ceramic materials  $B_4C$  powder and the fracture of  $Al_2O_3$  rods and tubes.

## CONCLUSION

High-gradient composite samples with  $B_4C$  powder filled  $Al_2O_3$  tubes suitable for ballistic tests were successfully processed. Main fracture mode of Ti-6Al-4V HIPed solid material is transgranular localization with subsequent crack formation. No cracking along grain boundaries was observed for the tests. Composite high-gradient sample demonstrated a capability to change a penetration path of long-rod penetrator and introduced new qualitative features of damage pattern, like forced shear localization in Ti-6Al-4V matrix under angle  $45^\circ$  to penetration path.

The main result of test with composite material shown in Figure 7 is that the projectile was deflected by the rows of rods and tubes. Heavily deformed remnants of the projectile completely sealed the crater in test 10470 where  $Al_2O_3$  rods were close to the impact surface. In test 10469 with the larger distance of rods from the surface the entrance diameter of the hole was similar to the experiments with homogeneous HIPed samples

(see References 2–6). This suggests that large entrance holes in homogeneous HIPed materials can be caused by target-induced yaw on the last stages of penetration. In addition to spontaneous shear bands resulting from instability of matrix material, the “forced” shear bands initiated by fracture of Al<sub>2</sub>O<sub>3</sub> tubes were also present (Figure 11). These shear bands are clearly transgranular. Interface layer on the boundary between Al<sub>2</sub>O<sub>3</sub> tubes and matrix during the penetration had multiple cracks that were arrested by matrix material (Figure 12).

High gradient composite materials can deflect long rod penetrator in optimized geometry and qualitatively change the fracture pattern of the target.

### ACKNOWLEDGMENT

The support provided by the ARO, MURI DAAH 04-96-1-0376 is highly appreciated.

### REFERENCES

1. Goldsmith, W. (1999). Non Ideal Projectile Impact on Targets, *International Journal of Impact Engineering*, **22**(2–3): 95–395.
2. Nesterenko, V.F., Indrakanti, S.S., Goldsmith, W. and Gu, Y. (2001). Plug Formation and Fracture of Hot Isostatically Pressed (HIPed) Ti-6Al-4V Targets, In: Staudhammer, K.P., Murr, L.E. and Meyers, M.A. (eds), *Fundamental Issues and Applications of Shock-Wave and High-Strain-Rate Phenomena*, pp. 593–600, Elsevier Science, Amsterdam.
3. Nesterenko, V.F., Indrakanti, S.S., Brar, S. and Gu, Y. (2000). Long Rod Penetration Test of Hot Isostatically Pressed Ti-based Targets, *Shock Compression of Condensed Matter, AIP Conference Proceedings*, **505**(1): 419–422.
4. Nesterenko, V.F., Indrakanti, S.S., Brar, S. and Gu, Y. (2000). Ballistic Performance of Hot Isostatically Pressed (HIPed) Ti-based Alloys, *Key Engng. Mater.*, **177–180**: 243–248.
5. Nesterenko, V.F., Goldsmith, W., Indrakanti, S.S. and Gu, Y. (2003). Response of Hot Isostatically Pressed Ti-6Al-4V Targets to Normal Impact by Conical and Blunt Projectiles, *International Journal of Impact Engineering*, **28**(2): 137–160.
6. Gu, Y., Indrakanti, S.S. and Nesterenko, V.F. (2002). Ballistic Testing and High-strain-rate Properties of Hot Isostatically Pressed Ti-6Al-4V, *Shock Compression of Condensed Matter, AIP Conference Proceedings*, **620**(1): 1294–1297.
7. Rupert, N.L. and Grace, F.I. (1995). Impact Studies of Rod Projectiles Against Titanium and Steel Targets, In: Murr, L.E., Staudhammer, K.P., and Meyers, M.A. (eds), *Metallurgical and Materials Applications of Shock-Wave and High-Strain-rate Phenomena*, pp. 257–264, Elsevier Science B.V., Amsterdam.
8. Goldsmith, W. (2001). *Impact: The Theory and Physical Behavior of Colliding Solids*, Dover Publications, Inc., Mineola, New York.